

SWISS-TYPE & CNC LATHE AUTOMATION SOLUTIONS

iSpeed3 Series

One Piece Type



Features

- Maximum 60,000 / 80,000 min-1 (rpm)
- Maximum Motor Power Output 140W / 150W
- Air-Cooled Motor to minimize heat buildup for continuous operation
- Spindle Accuracy within 1 um (TIR)
- Hardened and Precision Ground for Excellent Durability
- Simple screw-lock connector makes changing motors extremely easy

Outside Diameter Ø0.75", Ø0.79", Ø0.87" and Ø0.98"
(Ø19.05, Ø20, Ø22 and Ø25 mm)

1,000 ~ 80,000 min-1 (rpm)
Output 140W / 150W

- Short spindle length is suitable for compact sized automatic CNC lathes
- The iSpeed series have sensorless motors and are equipped with super precision hybrid ceramic bearings for long spindle life.

BM Type

Straight Type Motor Spindle
BM-319

Straight Type Motor Spindle
BM-320

Flange Type Motor Spindle
BM-320F

Straight Type Motor Spindle
BM-322

Flange Type Motor Spindle
BM-322FL / BM-322FR

Flange Type Motor Spindle
BM-322FS

Straight Type Motor Spindle
BM-325

Collet Nut CHN-A
Collet CHA-□□□

Automatic Control System Chart

- Sequential Operation of up to 2 Motor / Spindles
* 2 motors can not be operated simultaneously.

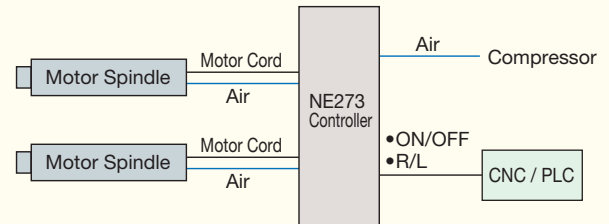

Motor Cord
(Cord with Quick Disconnect)
EMCD-BM3-3M / 5M / 7M *1
Page 2-p14

Controller
NE273

120V, 200V
230V, 100V

Compressor



Air Line Kit
AL-C1204

*Clean dry air is required.

SWISS-TYPE & CNC LATHE AUTOMATION SOLUTIONS

iSpeed3 Series

One Piece Type

BM Straight Type with Quick Disconnect Features

- Straight Type Motor/Spindle with pigtail for motor cords with quick-disconnect.
- Flange type motor spindles also available for machines with tool block with a blind hole.
- O.D. sizes for all Swiss type machines



CAT No. 7626 STRAIGHT TYPE MOTOR SPINDLE BM-319 80,000 min⁻¹(rpm)

Outside Diameter **Ø0.75" (Ø19.05"mm)**

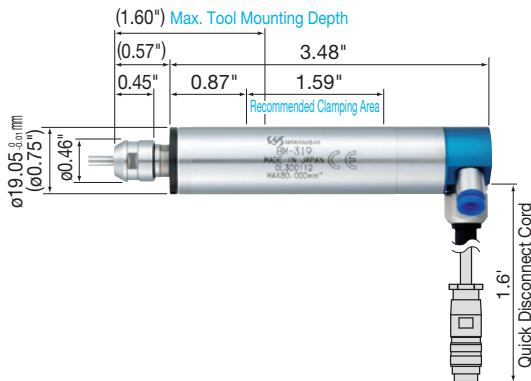

- Motor Speed 1,000~80,000 min⁻¹(rpm)
- Spindle Accuracy Within 1 µm
- Max Output Power 140W
- Standard Size Collet (CHA-3.175) Ø1/8"
- Weight 7.41 oz.

<Optional>

- Collet (CHA-XX) Ø0.5 mm~Ø4.0 mm (See Page 6-p2 for details)
- Motor Cord Length 10 ft, 16 ft, 22 ft

Straight Type Motor Spindle Ø0.75" (Ø19.05 mm)

CAT No.	Model	Standard Equipment	Price
7626	BM-319	<ul style="list-style-type: none"> • Collet Ø1/8" (CHA-3.175) : 1 pc • Collet Nut (CHN-A) : 1 pc • Wrench (8 x 5), (9, 11) : 1 pc ea 	\$2,805.00

CAT No. 7628 STRAIGHT TYPE MOTOR SPINDLE BM-320 80,000 min⁻¹(rpm)

Outside Diameter **Ø0.79" (Ø20"mm)**

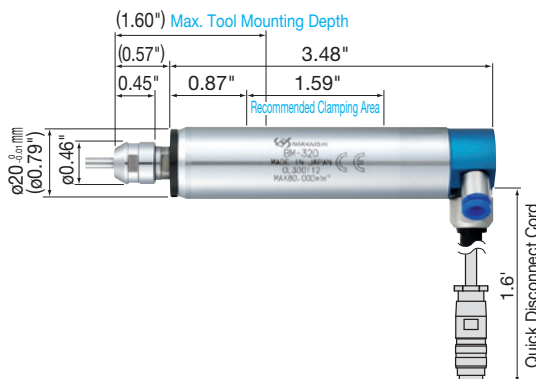

- Motor Speed 1,000~80,000 min⁻¹(rpm)
- Spindle Accuracy Within 1 µm
- Max Output Power 140W
- Standard Size Collet (CHA-3.175) Ø1/8"
- Weight 8.11 oz.

<Optional>

- Collet (CHA-XX) Ø0.5 mm~Ø4.0 mm (See Page 6-p2 for details)
- Motor Cord Length 10 ft, 16 ft, 22 ft

Straight Type Motor Spindle Ø0.75" (Ø19.05 mm)

CAT No.	Model	Standard Equipment	Price
7628	BM-320	<ul style="list-style-type: none"> • Collet Ø1/8" (CHA-3.175) : 1 pc • Collet Nut (CHN-A) : 1 pc • Wrench (8 x 5), (9, 11) : 1 pc ea 	\$2,805.00

Note: Motor Cords are sold separately.

Visit www.nskamericacorp.com for the complete offering.