

Cutting Tools

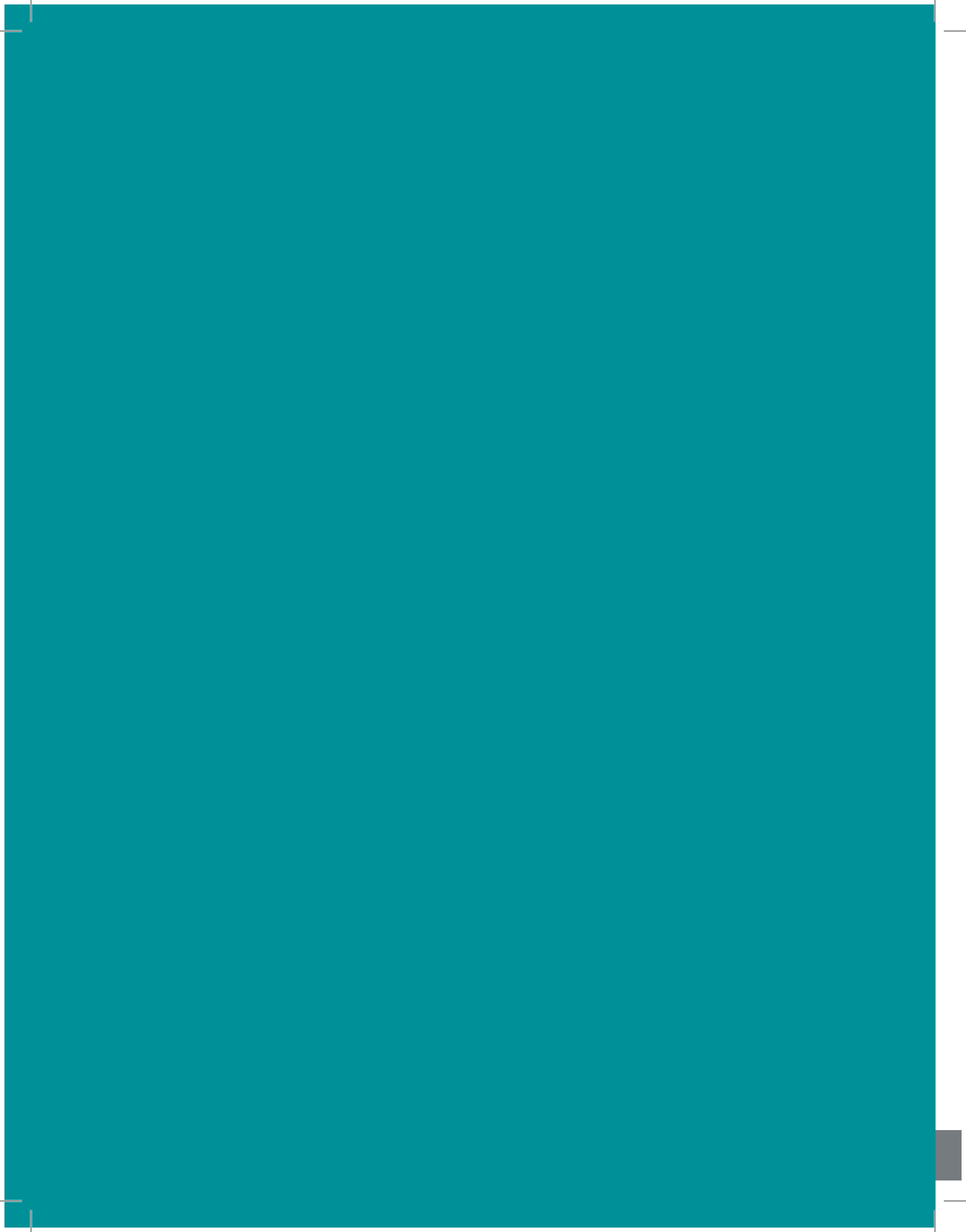

Creating Material Change
www.haydale.com  HaydaleGraphene



Contents

Our Story	4
The Pioneers – Whisker Reinforced Cutting Tools	5
Whiskered Ceramics	6
Cutting Tools for the Steel Mill Industry	7
Cutting Tools for Automotive Applications	7
Grade Information	8
Identification System	9
Grade for Workpiece	11
Roll Turning Inserts	12
Diamond Inserts, 80°, Negative, with hole	13
Diamond Inserts, 80°, Negative	14
Diamond Inserts, 80°, Negative, with dimple	15
Diamond Inserts, 55°, Negative, with hole	16
Diamond Inserts, 55°, Negative	17
Rectangular Inserts	18
Round Inserts, 7°, V-Bottom	19
Round Inserts, Negative	20
Round Inserts, Positive	21
Round Inserts, 11°, V-Bottom	22
Square Inserts, 90°, Negative, with hole	23
Square Inserts, 90°, Negative	24
Square Inserts, 90°, Negative, with dimple	25
Square Inserts, Positive	26
Triangle Inserts, 60°, Negative, with hole	27
Triangle Inserts, 60°, Negative	28
Diamond Inserts, 35°, Negative, with hole	29
Grooving and Side Turning Inserts	30
Trigon Inserts, 80°, Negative, with hole	31
Trigon Inserts, 80°, Negative	32
Square Inserts	33

Our Story

Haydale Ceramic Technologies (HCT) is a world leading manufacturer of Silicon Carbide (SiC) ceramic materials with the largest installed capacity for volume production across America, Europe and the APAC regions.

HCT developed the world's first whisker reinforced tools, and continues to lead in materials engineering and innovation in this category.

Produced in Greer, South Carolina, our cutting tools are manufactured using the highest quality SiC products, particulate, fibers and microfibers.

All our products are produced to stringent quality control procedures, managed by an experienced team offering dedicated support from consultancy through to materials development and application.



The Pioneers – Whisker Reinforced Cutting Tools

History Timeline

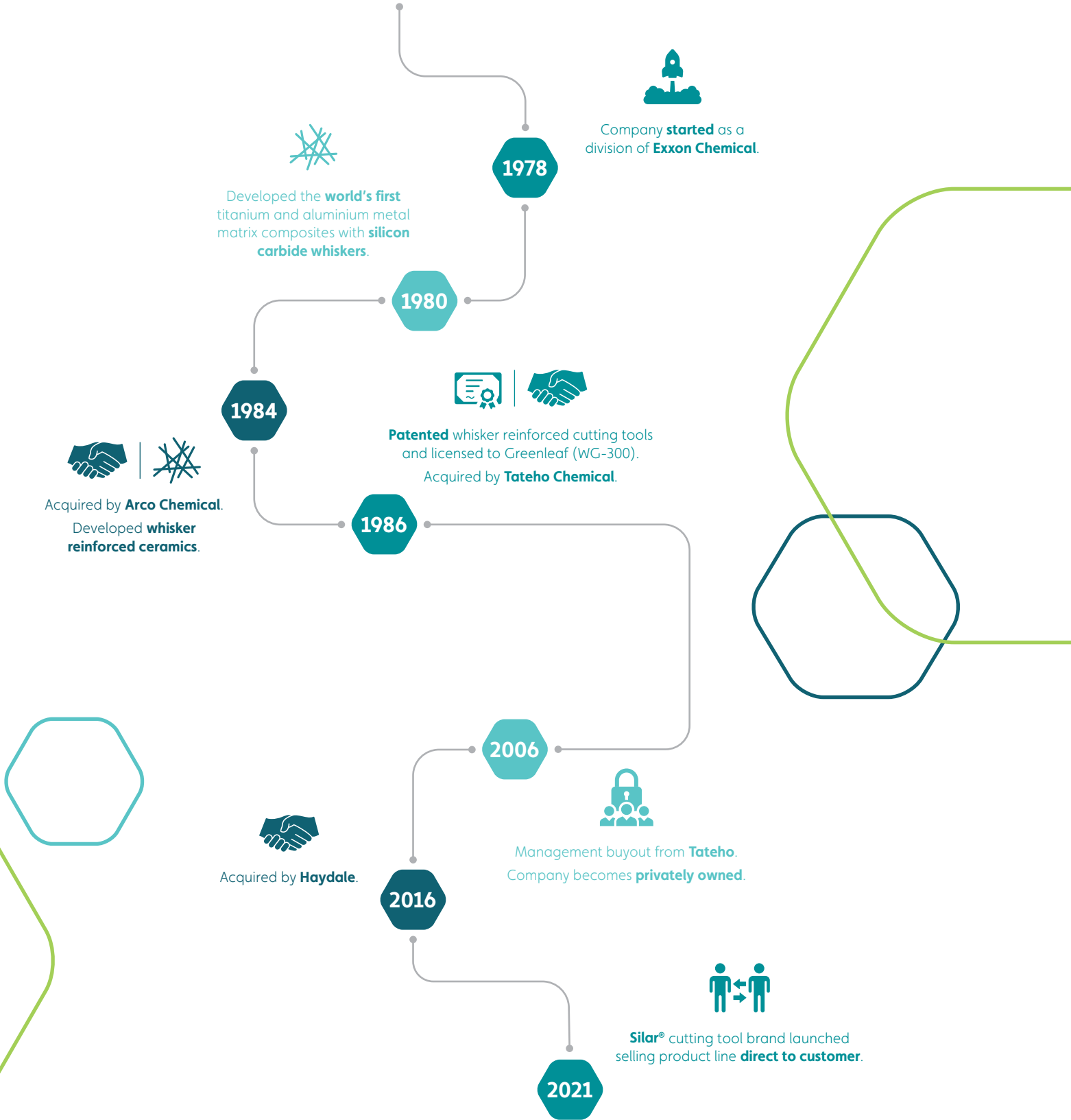

Whiskered Ceramics

Haydale's silicon carbide (SiC) whiskers reinforce ceramic inserts to deliver world-class hardness and fracture toughness.

The inclusion of SiC provides hardness second only to diamond. Due to long range force distribution provided by the fibre, we are able to achieve this result while maintaining exceptional toughness.

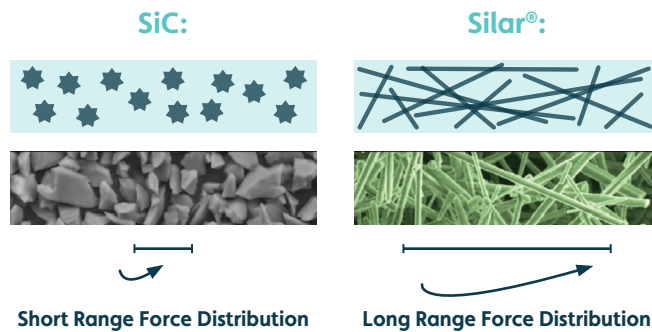

The selection of cutting tool substrate and grade is a key factor to consider when planning a successful metal cutting operation.

High cutting forces and high heat cause the metal to plasticize while the Silar® ceramic substrate remains in-tact.

Whisker-reinforced cutting tools offer both increased toughness and wear resistance, making them ideal for machining a variety of workpiece materials including Ni-based alloys, cobalt-based alloys, hardened steels, gray cast, ductile, and nodular irons, and mill rolls.

Enhanced Cutting Tools

Haydale is manufacturing the next generation of cutting tools for a range of applications in aerospace, steel mill roll turning and automotive.

Our SiC whisker-reinforced cutting tools are manufactured using Haydale's Silar® silicon carbide whiskers and offer enhanced features including:

- More than 10x the metal removal rate compared to traditional tungsten carbide cutting tools
- Excellent fracture resistance
- Increased hardness and toughness
- Extreme heat and wear resistance
- Dimensional stability
- New and novel CT-10 grade of whiskered tools that delivers superior surface finish compared to traditional whisker tools



Uses

Aerospace – Jet Engine Cases & Components (Nozzles, Vanes, Shafts, Turbines, Cases, etc.).

Energy – Machining of Steam Turbines & Components for Power Generation.

Heavy Turning – Steel Mill Work Rolls, Back-up Rolls, Paper Machine Rolls, Calendar Rolls, Super-Calendar Rolls, Tube & Pipe Forming Rolls, etc.

Automotive – Cast Iron, Ductile Iron, CGI, Hardened Steels, White Iron, Chilled Iron, and Powdered Metals.



Products

The Need for Speed – Aerospace Inserts

Our Silar® whisker reinforced ceramic cutting tools are designed for heavy material removal in roughing and semi-finishing applications.

They offer the perfect solution for high-speed machining of heat resistant super alloys (HRSA) – Inconel, Waspalloy, Haynes, Monel, Rene, Incoloy, A-286, Nimonic, Udimet, etc.

The Silar® CT-25 Grade offers a comprehensive and advanced range of high-speed cutting tool solutions for:

- Increased speed capability (more than ten times compared to carbide cutting tools) for higher throughput and shorter cycle times
- Increased toughness and fracture resistance for higher feed rate capability
- Increased variety and sharper edge preparations
- Efficient cutting
- Longer tool life
- Superior performance in continuous cutting conditions
- Capable of both wet and dry machining
- Ideal for heavily interrupted cutting

As demand for lightweight materials in the aerospace industry increases, Haydale can manufacture new grades and tooling that specialize in machining hard-to-cut materials.

With higher speed and feed rates, Silar® cutting tools deliver consistent results and longer tool life in applications for:

- Rough turning (O.D. & I.D.)
- Semi finishing (O.D. & I.D.)
- Milling
- Grooving

Cutting Tools for the Steel Mill Industry

The quality of inserts is as important as the machinery and workpiece.

Designed to protect your workpiece from damage caused by extreme heat and force and ensuring longer tool life, Haydale's steel mill inserts offer an optimal choice for milling fracking blocks and for milling flats on mill roll necks.

Steel mill geometries are used to remove heavy material in the most demanding rough turning conditions. Inserts are available for:

- Nodular iron mill rolls
- Hardened steel mill rolls
- Ductile iron mill rolls
- Stainless steel weld overlays / repair work on mill rolls
- Back up rolls
- D2 hardened tool steel

An alternative milling option to cermet and carbide tools, steel mill inserts are the first choice for:

- High speed hard milling
- High speed milling of mild steels commonly used for mill roll necks
- High speed milling of mild steels widely used in fracking block manufacturing
- Positive geometries for burr reduction in hard milling
- Unique edge prep geometries
- Increased productivity due to high speed and feed rates
- Rough turning (30 HRC +)
- Milling (30 HRC +)
- Tube milling scarfing tools for a wide range of pipe diameters, mill roll turning (both work rolls and back up rolls)

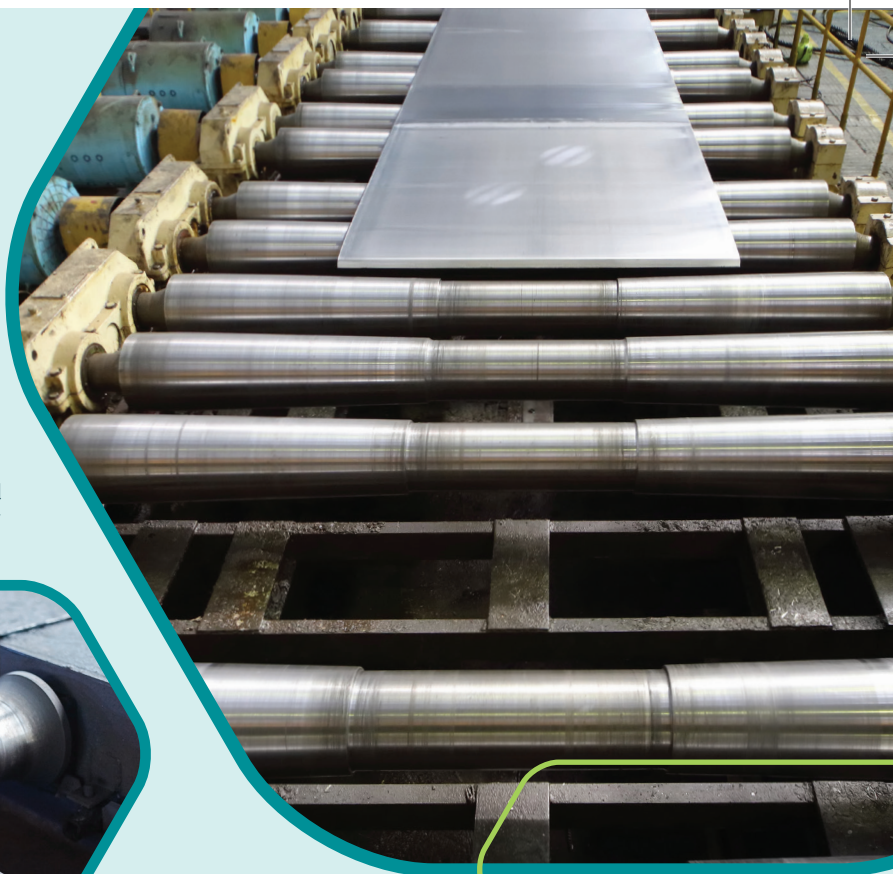

Cutting Tools for Automotive Applications

It is essential for turning and milling tools in automotive applications to wear evenly with minimal maintenance in the most demanding applications.

To meet the workflow and high output demands, Haydale has a range of inserts for the automotive industry using SiC whiskers that are long-lasting and deliver consistent and reliable results as well as:

- High Fracture resistance for consistent cutting in interrupted and continuous operations
- High DOC capability (Max .100")
- Speed capability of 2,400+ SFM in cast iron
- Feed rate capability of .018" + IPR

Our Silar® inserts are designed for heavy DOC material removal in cast iron, compacted graphite iron (CGI), ductile iron, nodular iron, hardened steels (transmission components), white iron, chilled iron, and powdered metals. Our high hardness allows us to machine these extremely abrasive materials with extended tool life vs. traditional ceramics. We offer several types and grades of materials for a range of products to suit specific automotive applications including:

- Brake rotors and ductile iron brake drums
- Carriers
- Dampers
- Pulleys
- Gear boxes
- Transmission covers
- Cylinder liner sleeves
- Flywheels, etc.



Grade Information

Product*	Ceramic Type	Description	
CT-10 CT-10C	SiC Whisker Reinforced	NEW! Excellent fracture toughness with a superior finish than CT-25	
CT-25 CT-25C			Unsurpassed toughness used primarily for roughing
SBN-550 SBN-550C		Cubic Boron Nitride	Low Content Solid CBN for use in hardened steel applications
SBN-570 SBN-570C		High Content Solid CBN Ideal for cast and ductile irons and abrasive materials	

Silicon Nitride, Sialon, and Alumina-TiC Ceramics are available upon request.

*All grades designated with a C suffix are coated.

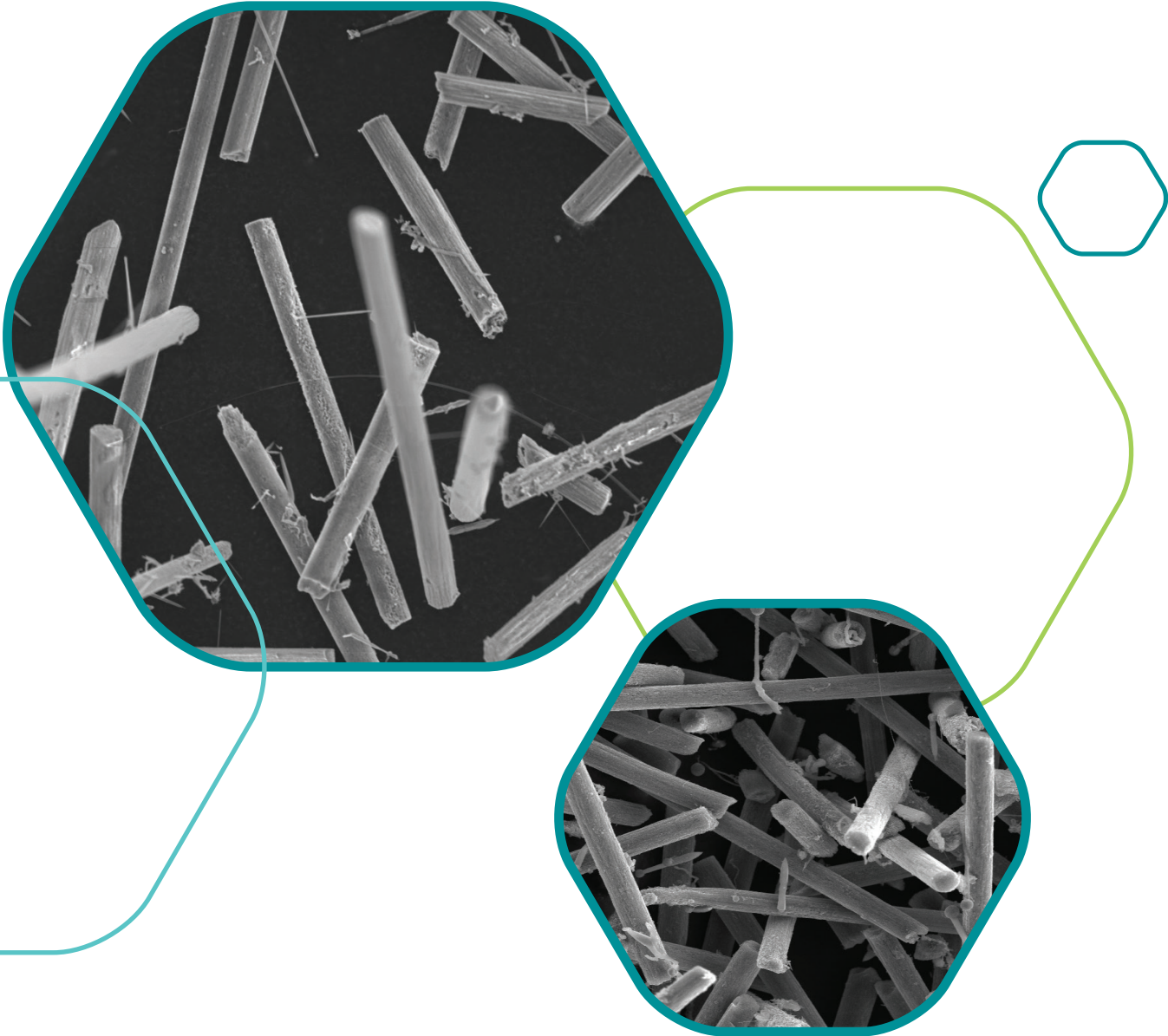

Identification System

ISO	C	N	G	A	12	04	08	Z	015	20	
ANSI	C	N	G	A	4	3	2	T	006	20	E1
	1	2	3	4	5	6	7	8	9	10	11

1. Shape

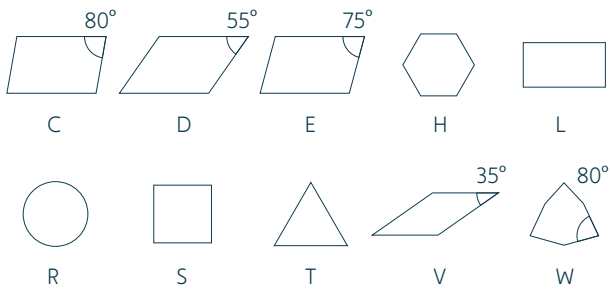

2. Clearance Angle

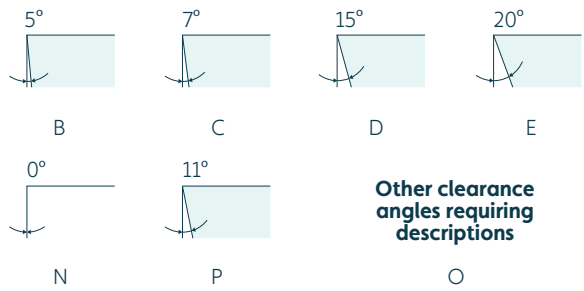

3. Tolerance

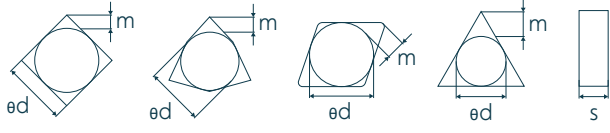

* See tables below

Symbol	d (mm)	m (mm)	s (mm)
A	±0.025	±0.005	±0.025
C	±0.025	±0.013	±0.025
E	±0.025	±0.025	±0.025
F	±0.013	±0.005	±0.025
G	±0.025	±0.025	±0.130
H	±0.013	±0.013	±0.025
J	*	±0.005	±0.025
K	*	±0.013	±0.025
L	*	±0.025	±0.025
M	*	*	±0.127
U	*	*	±0.127
N	*	*	±0.025

Symbol	D		C, E, H, O, S, T, R, W			
	d (mm)	m (mm)	d (mm)		m (mm)	
	M, N	M, N	J, K, L, M, N	U	M, N	U
5.56	±0.05	±0.11	±0.05	±0.08	±0.08	±0.13
6.35	±0.05	±0.11	±0.05	±0.08	±0.08	±0.13
7.94	±0.05	±0.11	±0.05	±0.08	±0.08	±0.13
9.52	±0.05	±0.11	±0.05	±0.08	±0.08	±0.13
12.70	±0.08	±0.15	±0.08	±0.13	±0.13	±0.20
15.87	±0.10	±0.18	±0.10	±0.18	±0.15	±0.27
19.05	±0.10	±0.18	±0.10	±0.18	±0.15	±0.27
25.40	-	-	±0.13	±0.25	±0.18	±0.38

4. Type

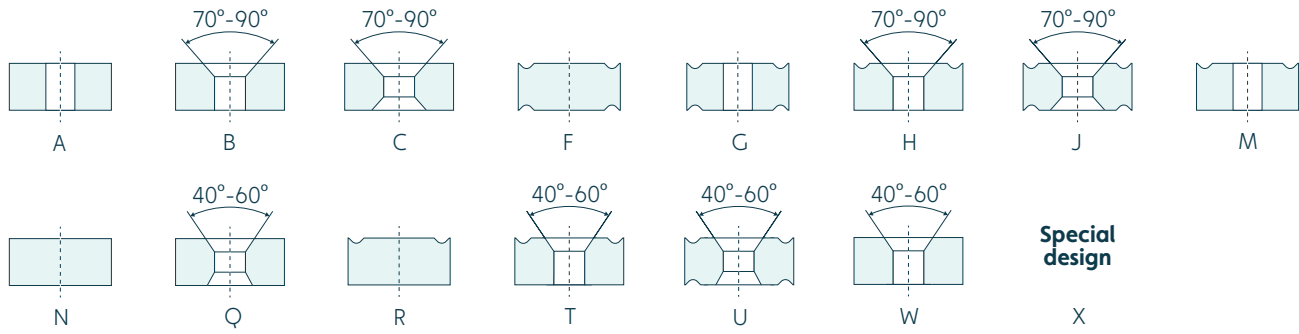

5. Insert size and edge length

ANSI (in)	ISO						
	C	D	R	S	T	Y	W
1/4"	2	06	07	06	11	11	04
3/8"	3	09	11	09	16	16	06
1/2"	4	12	15	12	22	22	08
5/8"	5	16	19	15	27	27	10
3/4"	6	19	23	19	33	33	13
1"	8	25	31	25	44	44	17

6. Thickness

Thickness (in)	ANSI	ISO
3/32"	1.5	02
1/8"	2	03
5/32"	2.5	T3
3/16"	3	04
1/4"	4	06
5/16"	5	07
3/8"	6	09
1/2"	8	12

7. Nose radius

Radius (in)	ANSI	ISO
1/64"	1	04
1/32"	2	08
3/64"	3	12
1/16"	4	16
5/64"	5	20
3/32"	6	24
1/8"	8	32

9, 10, 11. Edge prep

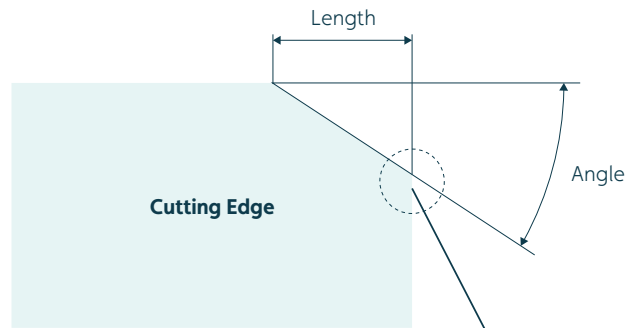

CNGA 120408 Z 015 20
CNGA 432 T 006 20 E1

9 Land Length

ANSI Length 006 0.006"
ISO Length 015 0.15mm

10 Land Angle

20: 20 degrees

11 Hone

ANSI Length E1 0.001"
ISO Length Z 0.025mm

8. Edge preparation

Edge	ANSI	ISO
Honed	E1 E2	E
Chamfered only	T	T
Chamfered and Honed	T with E1 at end (0.001" hone) T with E2 at end (0.002" hone)	Z (0.025 mm hone) S (0.050 mm hone)
Double Chamfered and Honed	HD	HD

Grade for Workpiece

Turning							
Application	Workpiece	Grade	Ceramic	Type	Speed	Feed	Depth of Cut
Turning	Gray Cast Iron, Chilled Cast Iron	CT-25 CT-25C	SiC Whisker	Rough	1,200 – 2,400 sfm	.008 - .024 ipr	.020" - .100"
		CT-10 CT-10C	SiC Whisker	Finish	600 – 1,200 sfm	.004 - .012 ipr	.010" - .020"
		SBN-570 SBN-570C	CBN	Rough	1,200 – 4,000 sfm	.010 - .020 ipr	.020" - .120"
		SBN-570 SBN-570C	CBN	Finish	1,200 – 4,000 sfm	.002 - .012 ipr	.006" - .020"
Turning	Ductile Iron Nodular Iron	CT-25 CT-25C	SiC Whisker	Rough	600 – 1,800 sfm	.006 - .018 ipr	.020" - .080"
		CT-10 CT-10C	SiC Whisker	Finish	600 – 1,600 sfm	.004 - .010 ipr	.010" - .020"
		SBN-550 SBN-550C	CBN	Rough	1,000 – 3,000 sfm	.008 - .016 ipr	.020" - .100"
		SBN-570 SBN-570C	CBN	Finish	1,000 – 3,000 sfm	.004 - .012 ipr	.010" - .020"
Turning	Tool Steel HRC 30-60	CT-25 CT-25C	SiC Whisker	Rough	300 – 1,000 sfm	.002 - .010 ipr	.010" - .040"
		CT-10 CT-10C	SiC Whisker	Finish	150 – 600 sfm	.002 - .010 ipr	.006" - .020"
	HRC 50+	SBN-550 SBN-550C	CBN	Rough	300 – 1,000 sfm	.002 - .010 ipr	.010" - .040"
		SBN-550 SBN-550C	CBN	Finish	300 – 1,000 sfm	.002 - .010 ipr	.006" - .020"
Turning	High Temperature Alloys (HTAs)	CT-25 CT-25C	SiC Whisker	Rough	600 – 1,600 sfm	.004 - .016 ipr	.020" - .120"
		CT-10 CT-10C	SiC Whisker	Finish	600 – 1,200 sfm	.004 - .010 ipr	.010" - .020"
		SBN-550 SBN-550C	CBN	Finish	600 – 1,200 sfm	.004 - .010 ipr	.010" - .020"

Milling							
Application	Workpiece	Grade	Ceramic	Type	Speed	Feed	Depth of Cut
Milling	Gray Cast Iron Chilled Cast Iron	CT-25 CT-25C	SiC Whisker	Rough	1,800 – 3,000 sfm	.004 - .010 ipt	.020" - .200"
		SBN-570 SBN-570C	CBN	Rough	2,000 – 4,000 sfm	.004 - .010 ipt	.020" - .200"
Milling	Ductile Iron Nodular Iron	CT-25 CT-25C	SiC Whisker	Rough	1,200 – 2,400 sfm	.004 - .008 ipt	.020" - .200"
		SBN-570 SBN-570C	CBN	Rough	1,600 – 4,000 sfm	.004 - .008 ipt	.020" - .200"
Milling	High Temperature Alloys (HTAs)	CT-25 CT-25C	SiC Whisker	Rough	1,800 – 3,600 sfm	.004 - .010 ipt	.040" - .120"

Parameters based on use of ½ I.C. Insert.

Roll Turning Inserts

Geometry	IC	T	H
CDH 22	1/2	1/4	0.125
CDH 33	3/4	3/8	0.250
CDH 42	1	1/2	0.266
CDH 515	1 1/4	3/8	0.391
CDH 53	1 1/4	3/4	0.391

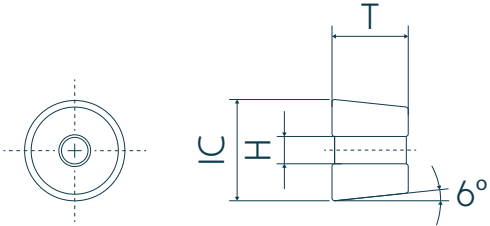
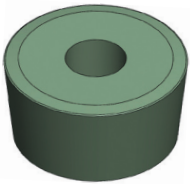

ANSI Designation		ISO Designation		Grades	
Tool	Edge Prep	Tool	Edge Prep	CT-10 (C)	CT-25 (C)
CDH 22	HD02810	CDH 22	HD0710	■	■
CDH 33	HD06010E2	CDH 33	HD1510E2	■	■
CDH 42	HD08015E1	CDH 42	HD2015E1	■	■
CDH 515	HD07110	CDH 515	HD1810	■	■

Standard
 Non-stock standard - call for availability

Diamond Inserts, 80°, Negative, with hole

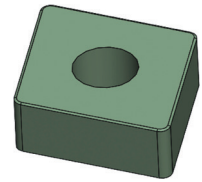

Geometry	IC	T	R
CNGA 432	1/2	3/16	0.031
CNGA 433	1/2	3/16	0.047
CNGA 434	1/2	3/16	0.063
CNGA 543	5/8	1/4	0.047
CNGA 544	5/8	1/4	0.063
CNGA 643	3/4	1/4	0.047

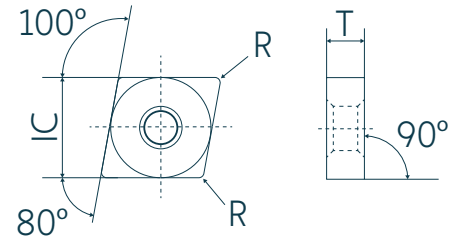

ANSI Designation		ISO Designation		Grades	
Tool	Edge Prep	Tool	Edge Prep	CT-25 (C)	CT-10 (C)
CNGA 432	T00220	CNGA 120408	T00520	■	■
CNGA 432	T00425	CNGA 120408	T01025	■	■
CNGA 432	T00825	CNGA 120408	T02025	■	■
CNGA 433	T00220	CNGA 120412	T00520	■	■
CNGA 433	T00425	CNGA 120412	T01025	■	■
CNGA 433	T00825	CNGA 120412	T02025	■	■
CNGA 434	T00220	CNGA 120416	T00520	■	■
CNGA 434	T00425	CNGA 120416	T01025	■	■
CNGA 434	T00825	CNGA 120416	T02025	■	■
CNGA 543	T00220	CNGA 160612	T00520	■	■
CNGA 544	T00425	CNGA 160616	T01025	■	■
CNGA 643	T00620	CNGA 190612	T01520	■	■
CNGA 643	T00620E1	CNGA 190612	Z01520	■	■

- Standard
- Non-stock standard - call for availability

Diamond Inserts, 80°, Negative

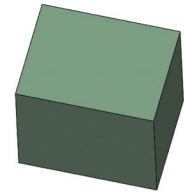

Geometry	IC	T	R
CNGN 432	1/2	3/16	0.031
CNGN 433	1/2	3/16	0.047
CNGN 434	1/2	3/16	0.063
CNGN 452	1/2	5/16	0.031
CNGN 453	1/2	5/16	0.047
CNGN 454	1/2	5/16	0.063

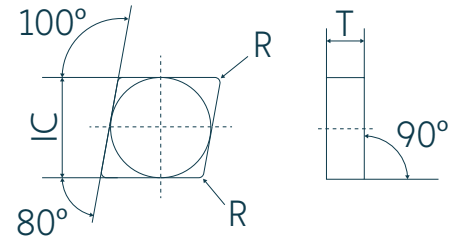

ANSI Designation		ISO Designation		Grades			
Tool	Edge Prep	Tool	Edge Prep	CT-25 (C)	CT-10 (C)	SBN-550 (C)	SBN-570 (C)
CNGN 432	T00220	CNGN 120408	T00520	■	■	□	□
CNGN 432	T00425	CNGN 120408	T01025	■	■	□	□
CNGN 432	T00825	CNGN 120408	T02025	■	■	□	□
CNGN 432	T00820 E2	CNGN 120408	S02020	□	□	■	■
CNGN 433	T00220	CNGN 120412	T00520	■	■	□	□
CNGN 433	T00425	CNGN 120412	T01025	■	■	□	□
CNGN 433	T00825	CNGN 120412	T02025	■	■	□	□
CNGN 433	T00820 E2	CNGN 120412	S02020	□	□	■	■
CNGN 434	T00220	CNGN 120416	T00520	■	■	□	□
CNGN 434	T00425	CNGN 120416	T01025	■	■	□	□
CNGN 434	T00825	CNGN 120416	T02025	■	■	□	□
CNGN 434	T00820 E2	CNGN 120416	S02020	□	□	■	■
CNGN 452	T00220	CNGN 120708	T00520	■	■	□	□
CNGN 452	T00425	CNGN 120708	T01025	■	■	□	□
CNGN 452	T00825	CNGN 120708	T02025	■	■	□	□
CNGN 452	T00820 E2	CNGN 120708	S02020	□	□	■	■
CNGN 453	T00220	CNGN 120712	T00520	■	■	□	□
CNGN 453	T00425	CNGN 120712	T01025	■	■	□	□
CNGN 453	T00825	CNGN 120712	T02025	■	■	□	□
CNGN 453	T00820 E2	CNGN 120712	S02020	□	□	■	■
CNGN 454	T00220	CNGN 120716	T00520	■	■	□	□
CNGN 454	T00425	CNGN 120716	T01025	■	■	□	□
CNGN 454	T00825	CNGN 120716	T02025	■	■	□	□
CNGN 454	T00820 E2	CNGN 120716	S02020	□	□	■	■

■ Standard

□ Non-stock standard - call for availability

Diamond Inserts, 80°, Negative, with dimple

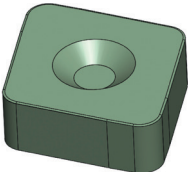

Geometry	IC	T	R
CNGX 432	1/2	3/16	0.031
CNGX 433	1/2	3/16	0.047
CNGX434	1/2	3/16	0.063
CNGX 452	1/2	5/16	0.031
CNGX 453	1/2	5/16	0.047
CNGX 454	1/2	5/16	0.063

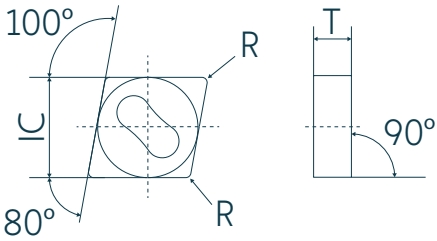

ANSI Designation		ISO Designation		Grades			
Tool	Edge Prep	Tool	Edge Prep	CT-10 (C)	CT-25 (C)	SBN-550 (C)	SBN-570 (C)
CNGX 432	T00820 E2	CNGX 120408	S02020	<input type="checkbox"/>	<input type="checkbox"/>	<input checked="" type="checkbox"/>	<input checked="" type="checkbox"/>
CNGX 433	T00820 E2	CNGX 120412	S02020	<input type="checkbox"/>	<input type="checkbox"/>	<input checked="" type="checkbox"/>	<input checked="" type="checkbox"/>
CNGX 434	T00820 E2	CNGX 120416	S02020	<input type="checkbox"/>	<input type="checkbox"/>	<input checked="" type="checkbox"/>	<input checked="" type="checkbox"/>
CNGX 452	T000825	CNGX 120708	T02025	<input checked="" type="checkbox"/>	<input type="checkbox"/>	<input type="checkbox"/>	<input type="checkbox"/>
CNGX 453	T000825	CNGX 120712	T02025	<input checked="" type="checkbox"/>	<input type="checkbox"/>	<input type="checkbox"/>	<input type="checkbox"/>
CNGX 454	T000825	CNGX 120716	T02025	<input checked="" type="checkbox"/>	<input type="checkbox"/>	<input type="checkbox"/>	<input type="checkbox"/>

Standard
 Non-stock standard - call for availability

Diamond Inserts, 55°, Negative, with hole

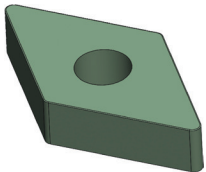

Geometry	IC	T	R
DNGA 432	1/2	3/16	0.031
DNGA 433	1/2	3/16	0.047
DNGA 434	1/2	3/16	0.063

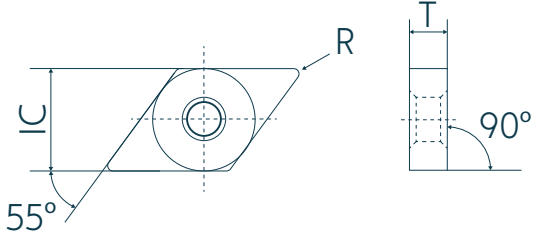

ANSI Designation		ISO Designation		Grades	
Tool	Edge Prep	Tool	Edge Prep	CT-10 (C)	CT-25 (C)
DNGA 432	T00220	DNGA 150408	T00520	■	■
DNGA 432	T00425	DNGA 150408	T01025	■	■
DNGA 433	T00220	DNGA 150412	T00520	■	■
DNGA 433	T00425	DNGA 150412	T01025	■	■
DNGA 434	T00220	DNGA 150416	T00520	■	■
DNGA 434	T00425	DNGA 150416	T01025	■	■

Standard
 Non-stock standard - call for availability

Diamond Inserts, 55°, Negative

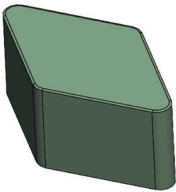

Geometry	IC	T	R
DNGN 432	1/2	3/16	0.031
DNGN 433	1/2	3/16	0.047
DNGN 434	1/2	3/16	0.063

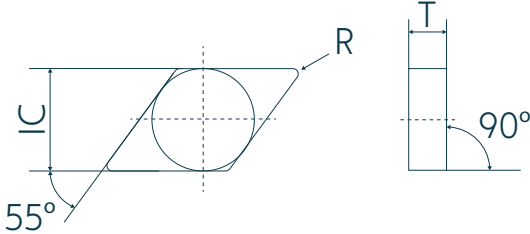

ANSI Designation		ISO Designation		Grades			
Tool	Edge Prep	Tool	Edge Prep	CT-10 (C)	CT-25 (C)	SBN-550 (C)	SBN-570 (C)
DNGN 432	T00220	DNGN 150408	T00520	■	■	□	□
DNGN 432	T00425	DNGN 150408	T01025	■	■	□	□
DNGN 432	T00820E2	DNGN 150408	S02020	□	□	■	■
DNGN 433	T00220	DNGN 150412	T00520	■	■	□	□
DNGN 433	T00425	DNGN 150412	T01025	■	■	□	□
DNGN 433	T00820E2	DNGN 150412	S02020	□	□	■	■
DNGN 434	T00220	DNGN 150416	T00520	■	■	□	□
DNGN 434	T00425	DNGN 150416	T01025	■	■	□	□
DNGN 433	T00820E2	DNGN 150416	S02020	□	□	■	■

■ Standard
 □ Non-stock standard - call for availability

Rectangular Inserts

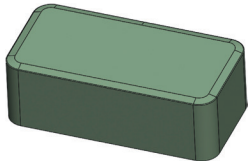

Geometry	W	L	T
LNJ 6688	3/4	1 1/2	1/2

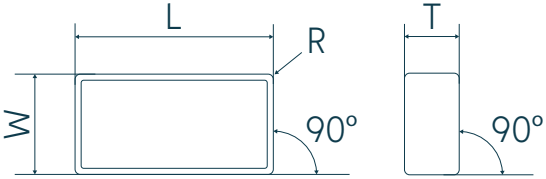

ANSI Designation		ISO Designation		Grades	
Tool	Edge Prep	Tool	Edge Prep	CT-10 (C)	CT-25 (C)
LNJ 6688	HD06015E1	LNJ 6688	HD1515E1	■	■
LNJ 6688	HD08015E2	LNJ 6688	HD2015E2	■	■

Standard
 Non-stock standard - call for availability

Round Inserts, 7°, V-Bottom

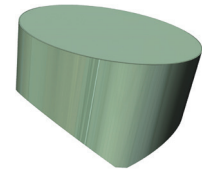

Geometry	IC	T	θ
RCGX 23	1/4	3/16	120°
RCGX 24	1/4	1/4	120°
RCGX 25	1/4	5/16	120°
RCGX 35	3/8	5/16	120°
RCGX 45	1/2	5/16	120°
RCGX 102	1/4	0.309	120°
RCGX 103	3/8	0.309	120°
RCGX 104	1/2	0.312	120°
RCGX 105	5/8	0.388	120°
RCGX 106	3/4	0.388	120°
RCGX 108	1	0.461	140°

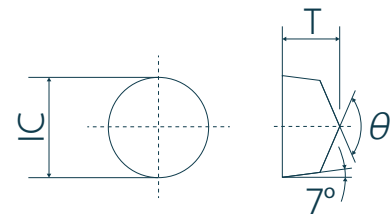

ANSI Designation		ISO Designation		Grades			
Tool	Edge Prep	Tool	Edge Prep	CT-10 (C)	CT-25 (C)	SBN-550 (C)	SBN-570 (C)
RCGX23	T00220	RCGX060400	T00520	■	■	□	□
RCGX23	T00220E1	RCGX060400	Z00520	■	■	□	□
RCGX23	T00425	RCGX060400	T01025	■	■	□	□
RCGX24	T00220	RCGX060600	T00520	■	■	□	□
RCGX24	T00220E1	RCGX060600	Z00520	■	■	□	□
RCGX24	T00425	RCGX060600	T01025	■	■	□	□
RCGX35	T00220	RCGX090700	T00520	■	■	□	□
RCGX35	T00220E1	RCGX090700	Z00520	■	■	□	□
RCGX35	T00425	RCGX090700	T01025	■	■	□	□
RCGX35	T00425E1	RCGX090700	Z01025	■	■	□	□
RCGX35	T00825	RCGX090700	T02025	■	■	□	□
RCGX35	T00825E1	RCGX090700	Z02025	■	■	□	□
RCGX45	T00220	RCGX120700	T00520	■	■	□	□
RCGX45	T00220E1	RCGX120700	Z00520	■	■	□	□
RCGX45	T00425	RCGX120700	T01025	■	■	□	□
RCGX45	T00425E1	RCGX120700	Z01025	■	■	□	□
RCGX45	T00825	RCGX120700	T02025	■	■	□	□
RCGX45	T00825E1	RCGX120700	Z02025	■	■	□	□
RCGX 102	HD04815E1	RCGX 102	HD1215E1	■	■	□	□
RCGX 102	T02020E2	RCGX 102	S05020	□	□	■	■
RCGX 103	HD04815E1	RCGX 103	HD1215E1	■	■	□	□
RCGX 103	T02020E2	RCGX 103	S05020	□	□	■	■
RCGX 104	HD06015E1	RCGX 104	HD1515E1	■	■	□	□
RCGX 104	T02020E2	RCGX 104	S05020	□	□	■	■
RCGX 105	HD08015E1	RCGX 105	HD2015E1	■	■	□	□
RCGX 105	T02020E2	RCGX 105	S05020	□	□	■	■
RCGX 106	HD08015E1	RCGX 106	HD2015E1	■	■	□	□
RCGX 106	T02020E2	RCGX 106	S05020	□	□	■	■
RCGX 108	HD06015E1	RCGX 108	HD1515E1	■	■	□	□
RCGX 108	T02020E2	RCGX 108	S05020	□	□	■	■

■ Standard
 □ Non-stock standard - call for availability

Round Inserts, Negative

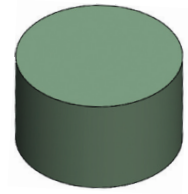

Geometry	IC	T
RNGN 32	3/8	1/8
RNGN 33	3/8	3/16
RNGN 43	1/2	3/16
RNGN 45	1/2	5/16
RNGN 55	5/8	5/16
RNGN 64	3/4	1/4
RNGN 65	3/4	5/16
RNGN 85	1	5/16
RNGN 86	1	3/8
RNGN 106	1 1/4	3/8

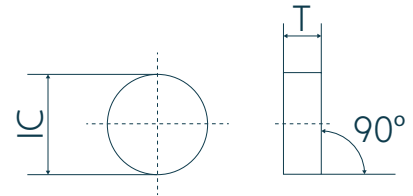

ANSI Designation		ISO Designation		Grades			
Tool	Edge Prep	Tool	Edge Prep	CT-10 (C)	CT-25 (C)	SBN-550 (C)	SBN-570 (C)
RNGN 32	T00220	RNGN 090300	T00520	■	■	■	■
RNGN 33	T00220	RNGN 090400	T00520	■	■	■	■
RNGN 43	T00220	RNGN 120400	T00520	■	■	■	■
RNGN 43	T00425	RNGN 120400	T01025	■	■	■	■
RNGN 45	T00220	RNGN 120700	T00520	■	■	■	■
RNGN 45	T00620E1	RNGN 120700	Z01520	■	■	■	■
RNGN 55	T00220	RNGN 150700	T00520	■	■	■	■
RNGN 64	T00825	RNGN 190600	T02025	■	■	■	■
RNGN 65	T00220	RNGN 190700	T00520	■	■	■	■
RNGN 85	T00220	RNGN 250700	T00520	□	□	□	□
RNGN 86	T00220	RNGN 250900	T00520	□	□	□	□
RNGN 86	HD090515E2	RNGN 250900	HD2415E2	□	□	□	□
RNGN 106	HD090515E2	RNGN 310900	HD2415E2	□	□	□	□

■ Standard
 □ Non-stock standard - call for availability

Round Inserts, Positive

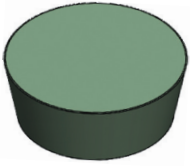

Geometry	IC	T
RPGN 215	1/4	3/32
RPGN 32	3/8	1/8
RPGN 43	1/2	3/16

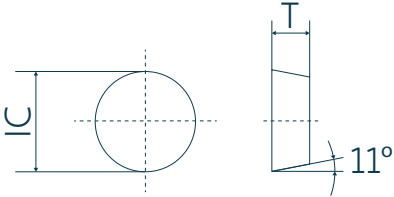

ANSI Designation		ISO Designation		Grades			
Tool	Edge Prep	Tool	Edge Prep	CT-10 (C)	CT-25 (C)	SBN-550 (C)	SBN-570 (C)
RPGN 215	T00220	RPG 060200	T00520	☐	☐	☐	☐
RPGN 32	T00220	RPG 090300	T00520	☐	☐	☐	☐
RPGN 43	T00220	RPG 120400	T00520	■	■	■	■
RPGN 43	T00425	RPG 120400	T01025	☐	☐	☐	☐

■ Standard
 ☐ Non-stock standard - call for availability

Round Inserts, 11°, V-Bottom

Geometry	IC	T	θ
RPGX 23	1/4	3/16	120°
RPGX 35	3/8	5/16	120°
RPGX 45	1/2	5/16	120°

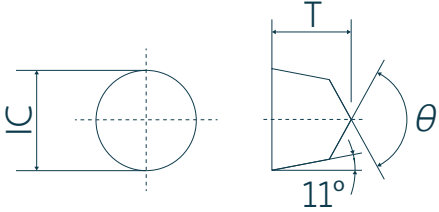
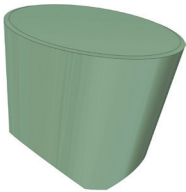

ANSI Designation		ISO Designation		Grades	
Tool	Edge Prep	Tool	Edge Prep	CT-10 (C)	CT-25 (C)
RPGX 23	T00220	RPGX 0604	T00520	■	■
RPGX 23	T00420E1	RPGX 0604	Z01020	■	■
RPGX 35	T00220	RPGX 0907	T00520	■	■
RPGX 45	T00220	RPGX 120700	T00520	■	■

Standard
 Non-stock standard - call for availability

Square Inserts, 90°, Negative, with hole

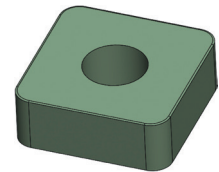

Geometry	IC	T	R
SNGA 432	1/2	3/16	0.031
SNGA 433	1/2	3/16	0.047
SNGA 434	1/2	3/16	0.063
SNGA 434	1/2	3/16	0.063
SNGA 543	5/8	1/4	0.047
SNGA 544	5/8	1/4	0.063
SNGA 644	3/4	1/4	0.064

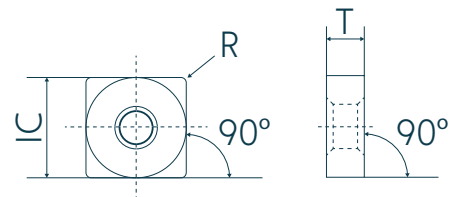

ANSI Designation		ISO Designation		Grades	
Tool	Edge Prep	Tool	Edge Prep	CT-10 (C)	CT-25 (C)
SNGA 432	T00220	SNGA 120408	T00520	■	■
SNGA 433	T00220	SNGA 120412	T00520	■	■
SNGA 434	T00220	SNGA 120416	T00520	■	■
SNGA 434	T00825	SNGA 120416	T02025	■	■
SNGA 543	T00220	SNGA 150612	T00520	■	■
SNGA 544	T00220	SNGA 150616	T00520	■	■
SNGA 644	T00825	SNGA 190616	T02025	■	■

- Standard
- Non-stock standard - call for availability

Square Inserts, 90°, Negative

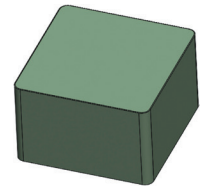

Geometry	IC	T	R
SNGN 432	1/2	3/16	0.031
SNGN 433	1/2	3/16	0.047
SNGN 434	1/2	3/16	0.063
SNGN 434	1/2	3/16	0.063
SNGN 437	1/2	3/16	0.109
SNGN 452	1/2	5/16	0.031
SNGN 453	1/2	5/16	0.047
SNGN 454	1/2	5/16	0.063
SNGN 543	5/8	1/4	0.047
SNGN 544	5/8	1/4	0.063
SNGN 644	3/4	1/4	0.063
SNGN 654	3/4	5/16	0.063

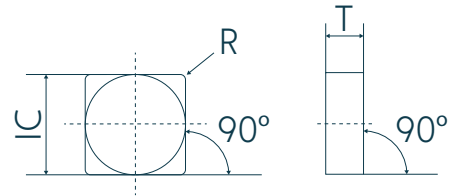

ANSI Designation		ISO Designation		Grades			
Tool	Edge Prep	Tool	Edge Prep	CT-10 (C)	CT-25 (C)	SBN-550 (C)	SBN-570 (C)
SNGN 432	T00220	SNGN 1200408	T00520	■	■	□	□
SNGN 432	T00425	SNGN 1200408	T01025	■	■	□	□
SNGN 432	T00825	SNGN 1200408	T02025	■	■	□	□
SNGN 432	T00820E2	SNGN 1200408	S02020	□	□	■	■
SNGN 433	T00220	SNGN 120412	T00520	■	■	□	□
SNGN 433	T00425	SNGN 120412	T01025	■	■	□	□
SNGN 433	T00825	SNGN 120412	T02025	■	■	□	□
SNGN 433	T00820E2	SNGN 120412	S02020	□	□	■	■
SNGN 434	T00220	SNGN 120416	T00520	■	■	□	□
SNGN 434	T00425	SNGN 120416	T01025	■	■	□	□
SNGN 434	T00825	SNGN 120416	T02025	■	■	□	□
SNGN 434	T00820E2	SNGN 120416	S02020	□	□	■	■
SNGN 437	T00420	SNGN 120428	T01020	■	■	□	□
SNGN 452	T00220	SNGN 120708	T00520	■	■	□	□
SNGN 453	T00220	SNGN 120712	T00520	■	■	□	□
SNGN 454	T00220	SNGN 120716	T00520	■	■	□	□
SNGN 543	T00220	SNGN 150612	T00520	■	■	□	□
SNGN 643	T00220	SNGN 190612	T00520	■	■	□	□
SNGN 644	T00220	SNGN 190616	T00520	■	■	□	□
SNGN 654	T00220	SNGN 190716	T00520	■	■	□	□

■ Standard
 □ Non-stock standard - call for availability

Square Inserts, 90°, Negative, with dimple

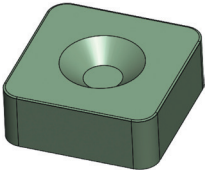

Geometry	IC	T	R
SNGX 432	1/2	3/16	0.031
SNGX 433	1/2	3/16	0.047
SNGX 434	1/2	3/16	0.063
SNGX 452	1/2	5/16	0.031
SNGX 453	1/2	5/16	0.047
SNGX 454	1/2	5/16	0.063

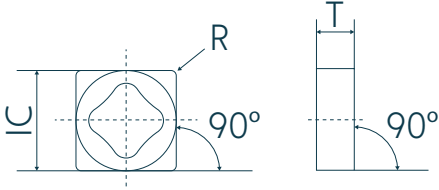

ANSI Designation		ISO Designation		Grades			
Tool	Edge Prep	Tool	Edge Prep	CT-10 (C)	CT-25 (C)	SBN-550 (C)	SBN-570 (C)
SNGX 432	T00820 E2	SNGX 120408	S02020	☐	☐	■	■
SNGX 433	T00820 E2	SNGX 120412	S02020	☐	☐	■	■
SNGX 434	T00820 E2	SNGX 120416	S02020	☐	☐	■	■
SNGX 452	T00825	SNGX 120708	T02025	■	☐	☐	☐
SNGX 453	T00825	SNGX 120712	T02025	■	☐	☐	☐
SNGX 454	T00825	SNGX 120716	T02025	■	☐	☐	☐

■ Standard
 ☐ Non-stock standard - call for availability

Square Inserts, Positive

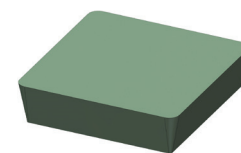

Geometry	IC	T	R
SPGN 322	3/8	1/8	0.031
SPGN 422	1/2	1/8	0.031
SPGN 432	1/2	3/16	0.031
SPGN 433	1/2	3/16	0.047
SPGN 434	1/2	3/16	0.063
SPGN 633	3/4	3/16	0.047
SPGN 634	3/4	3/16	0.063

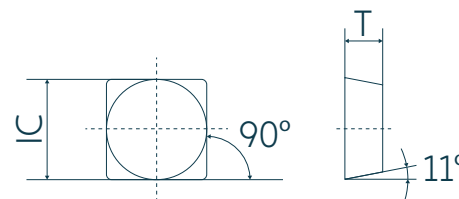

ANSI Designation		ISO Designation		Grades	
Tool	Edge Prep	Tool	Edge Prep	CT-10 (C)	CT-25 (C)
SPGN 322	T00220	SPGN 090308	T00520	□	□
SPGN 422	T00220	SPGN 120308	T00520	□	□
SPGN 432	T00220	SPGN 120408	T00520	■	■
SPGN 433	T00220	SPGN 120412	T00520	■	■
SPGN 434	T00220	SPGN 120416	T00520	■	■
SPGN 633	T00220	SPGN 190412	T00520	□	□
SPGN 634	T00220	SPGN 190416	T00520	□	□

- Standard
- Non-stock standard - call for availability

Triangle Inserts, 60°, Negative, with hole

Geometry	IC	T	R
TNGA 332	3/8	3/16	0.031
TNGA 432	1/2	3/16	0.031

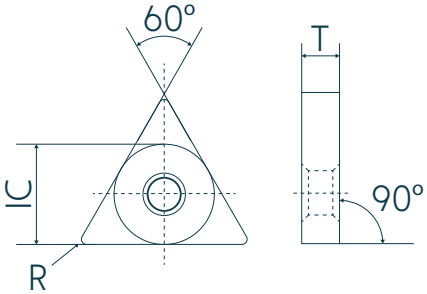
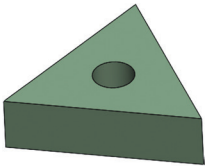

ANSI Designation		ISO Designation		Grades	
Tool	Edge Prep	Tool	Edge Prep	CT-10 (C)	CT-25 (C)
TNGA 332	T00220	TNGA 160408	T00520	■	■
TNGA 432	T00220	TNGA 220408	T00520	■	■
TNGA 432	T00425	TNGA 220408	T01025	■	■

Standard
 Non-stock standard - call for availability

Triangle Inserts, 60°, Negative

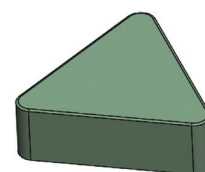

Geometry	IC	T	R
TNGN 332	3/8	3/16	0.031
TNGN 432	1/2	3/16	0.031
TNGN 433	1/2	3/16	0.047
TNGN 434	1/2	3/16	0.063
TNGN 453	1/2	5/16	0.047
TNGN 454	1/2	5/16	0.063

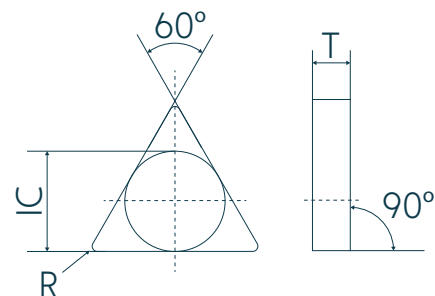

ANSI Designation		ISO Designation		Grades			
Tool	Edge Prep	Tool	Edge Prep	CT-10 (C)	CT-25 (C)	SBN-550 (C)	SBN-570 (C)
TNGN 332	T00220	TNGN 160408	T00520	■	■	□	□
TNGN 432	T00220	TNGN 220408	T00520	■	■	□	□
TNGN 432	T00820E2	TNGN 220408	S02025	□	□	■	■
TNGN 433	T00220	TNGN 220412	T00520	■	■	□	□
TNGN 433	T00820E2	TNGN 220412	S02025	□	□	■	■
TNGN 434	T00220	TNGN 220416	T00520	■	■	□	□
TNGN 434	T00820E2	TNGN 220416	S02025	□	□	■	■
TNGN 453	T00220	TNGN 220712	T00520	■	■	□	□
TNGN 454	T00220	TNGN 220716	T00520	■	■	□	□

■ Standard
 □ Non-stock standard - call for availability

Diamond Inserts, 35°, Negative, with hole

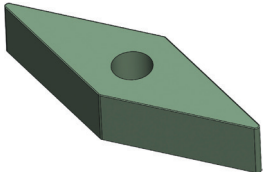

Geometry	IC	T	R
VNGA 332	3/8	3/16	0.031
VNGA 333	3/8	3/16	0.047
VNGA 432	1/2	3/16	0.031
VNGA 433	1/2	3/16	0.047

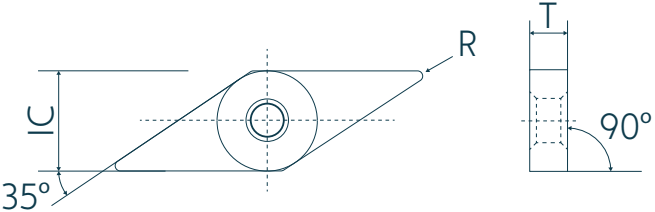

ANSI Designation		ISO Designation		Grades	
Tool	Edge Prep	Tool	Edge Prep	CT-10 (C)	CT-25 (C)
VNGA 332	T00220	VNGA 160408	T00520	■	■
VNGA 333	T00220	VNGA 160412	T00520	□	□
VNGA 432	T00220	VNGA 220408	T00520	■	■
VNGA 433	T00220	VNGA 220412	T00520	□	□

■ Standard
 □ Non-stock standard - call for availability

Grooving and Side Turning Inserts

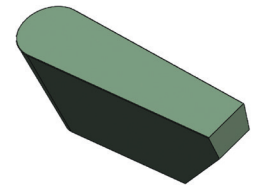

Geometry	W	L	T	R
VGW 4125-R	0.125	0.500	0.187	0.063
VGW 4125-1	0.125	0.500	0.187	0.016
VGW 4125-2	0.125	0.500	0.187	0.031
VGW 4156-R	0.156	0.500	0.187	0.078
VGW 4156-1	0.156	0.500	0.187	0.016
VGW 4156-2	0.156	0.500	0.187	0.031
VGW 4187-R	0.187	0.500	0.187	0.094
VGW 4187-1	0.187	0.500	0.187	0.016
VGW 4187-2	0.187	0.500	0.187	0.031
VGW 6218-R	0.218	0.750	0.250	0.109
VGW 6218-1	0.218	0.750	0.250	0.016
VGW 6218-2	0.218	0.750	0.250	0.031
VGW 6250-R	0.250	0.750	0.250	0.125
VGW 6250-1	0.250	0.750	0.250	0.016
VGW 6250-2	0.250	0.750	0.250	0.031
VGW 6250-3	0.250	0.750	0.250	0.047

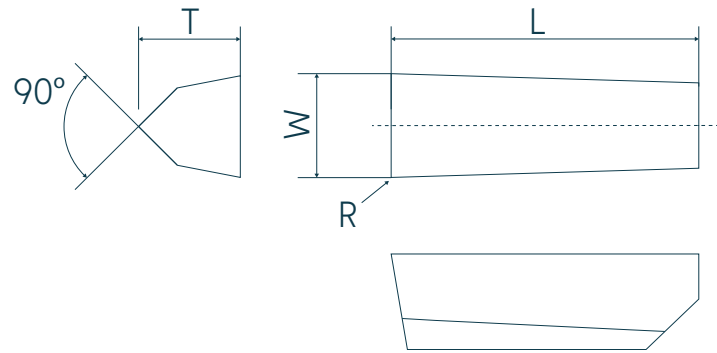

ANSI Designation		ISO Designation		Grades	
Tool	Edge Prep	Tool	Edge Prep	CT-10 (C)	CT-25 (C)
VGW 4125-R	E1	VGW 4125-R	E002	■	■
VGW 4125-1	E1	VGW 4125-1	E002	■	■
VGW 4125-2	E1	VGW 4125-2	E002	■	■
VGW 4156-R	E1	VGW 4156-R	E002	■	■
VGW 4156-1	E1	VGW 4156-1	E002	■	■
VGW 4156-2	E1	VGW 4156-2	E002	■	■
VGW 4187-R	E1	VGW 4187-R	E002	■	■
VGW 4187-1	E1	VGW 4187-1	E002	■	■
VGW 4187-2	E1	VGW 4187-2	E002	■	■
VGW 6218-R	E1	VGW 6218-R	E002	■	■
VGW 6218-1	E1	VGW 6218-1	E002	■	■
VGW 6218-2	E1	VGW 6218-2	E002	■	■
VGW 6250-R	E1	VGW 6250-R	E002	■	■
VGW 6250-1	E1	VGW 6250-1	E002	■	■
VGW 6250-2	E1	VGW 6250-2	E002	■	■
VGW 6250-3	E1	VGW 6250-3	E002	■	■

■ Standard

□ Non-stock standard - call for availability

Trigon Inserts, 80°, Negative, with hole

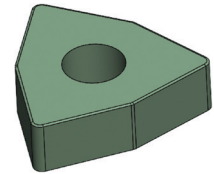

Geometry	IC	T	R
WNGA 332	3/8	3/16	0.031
WNGA 333	3/8	3/16	0.047
WNGA 431	1/2	3/16	0.016
WNGA 432	1/2	3/16	0.031
WNGA 433	1/2	3/16	0.047
WNGA 434	1/2	3/16	0.063

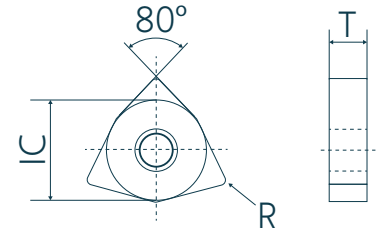

ANSI Designation		ISO Designation		Grades	
Tool	Edge Prep	Tool	Edge Prep	CT-10 (C)	CT-25 (C)
WNGA 332	T00220	WNGA 060408	T00520	<input type="checkbox"/>	<input type="checkbox"/>
WNGA 333	T00220	WNGA 060412	T00520	<input type="checkbox"/>	<input type="checkbox"/>
WNGA 431	T00220	WNGA 080404	T00520	<input type="checkbox"/>	<input type="checkbox"/>
WNGA 432	T00220	WNGA 080408	T00520	<input type="checkbox"/>	<input type="checkbox"/>
WNGA 433	T00220	WNGA 080412	T00520	<input type="checkbox"/>	<input type="checkbox"/>
WNGA 434	T00220	WNGA 080416	T00520	<input type="checkbox"/>	<input type="checkbox"/>

- Standard
- Non-stock standard - call for availability

Trigon Inserts, 80°, Negative

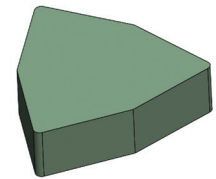

Geometry	IC	T	R
WNGN 332	3/8	3/16	0.031
WNGN 333	3/8	3/16	0.047
WNGN 431	1/2	3/16	0.016
WNGN 432	1/2	3/16	0.031
WNGN 433	1/2	3/16	0.047
WNGN 434	1/2	3/16	0.063

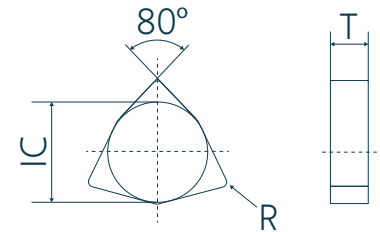

ANSI Designation		ISO Designation		Grades	
Tool	Edge Prep	Tool	Edge Prep	SBN-550 (C)	SBN-570 (C)
WNGN 332	T00820E2	WNGN 060408	S02025	■	■
WNGN 333	T00820E2	WNGN 060412	S02025	■	■
WNGN 431	T00820E2	WNGN 080404	S02025	■	■
WNGN 432	T00820E2	WNGN 080408	S02025	■	■
WNGN 433	T00820E2	WNGN 080412	S02025	■	■
WNGN 434	T00820E2	WNGN 080416	S02025	■	■

- Standard
- Non-stock standard - call for availability

Square Inserts

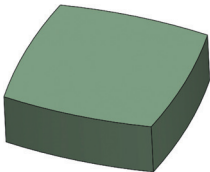

Geometry	IC	T	R
ZT-1130	1 1/2	1/2	4 1/2

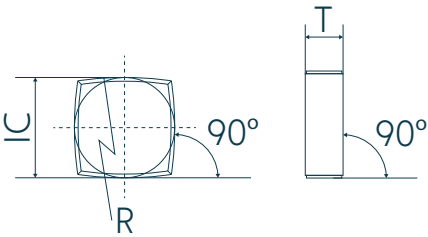

ANSI Designation		ISO Designation		Grades	
Tool	Edge Prep	Tool	Edge Prep	CT-10 (C)	CT-25 (C)
ZT-1130	HD09515E2	ZT-1130	HD2415E2	■	■

- Standard
- Non-stock standard - call for availability

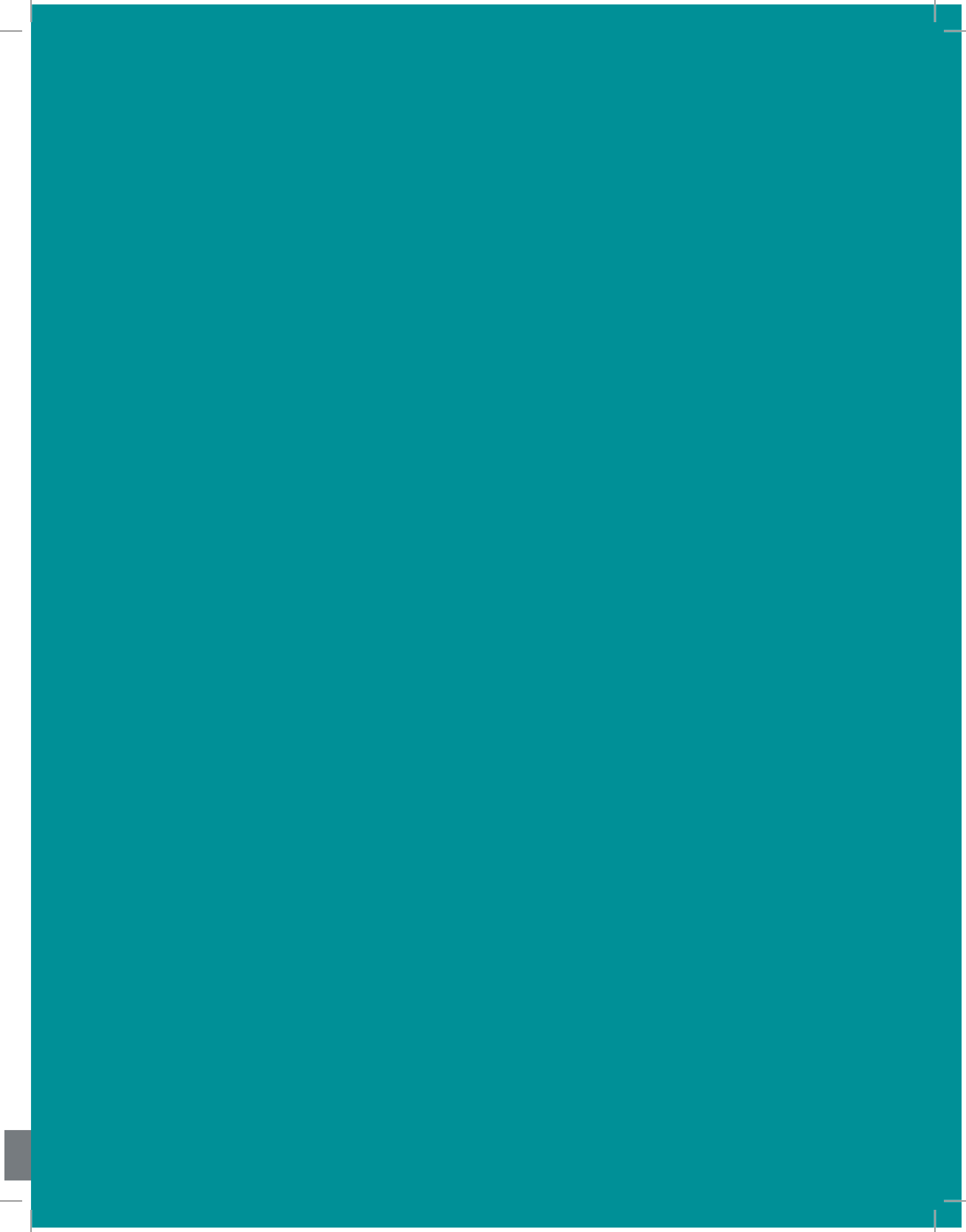

About Haydale

Creating Material Change

Contact us today for a solution that meets your specific requirements. Haydale is here to help with end-to-end support to ensure selection of the correct material for your specific application.

Get in touch with us to find out more.
Contact our US-based manufacturing centre.

Haydale Ceramic Technologies, LLC

1446 South Buncombe Road

Greer

South Carolina 29651

USA

T: +1 864 877 0123

E: silar@haydale.com

[haydale.com](https://www.haydale.com)



MADE IN THE USA

VERSION 1.5 MAY 2023

